

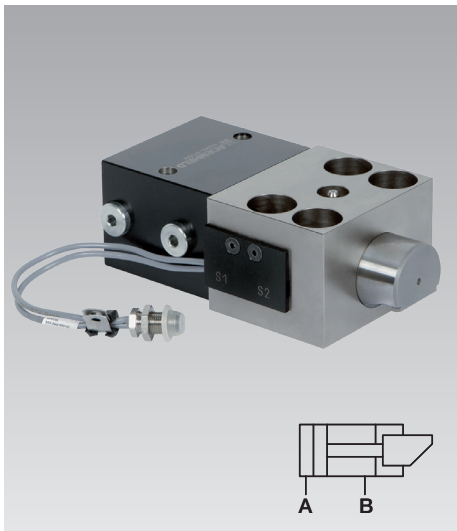

## Wedge Clamps for Tapered Clamping Edge

double acting, max. clamping force 50 to 400 kN,  
with form-fit safety step and position monitoring



### Advantages

- Safety step for form-fit holding of dies or moulds when the pressure drops
- Safe clamping of moulds/dies with tapered clamping edge
- High operational safety by position monitoring and automatic motion sequence
- Very sturdy design
- High safety standard
- Long service life
- Patented design

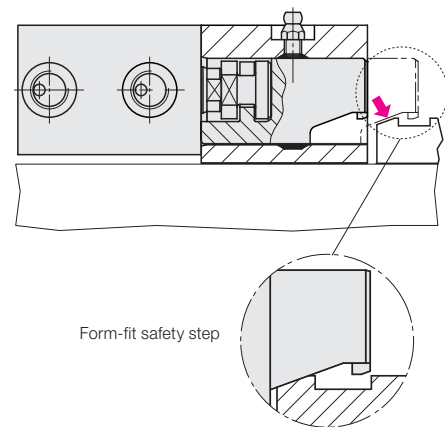

Form-fit safety step

### Application

Double-acting wedge clamp with a form-fit safety lug at the clamping bolt for clamping dies on a press bed or ram or for clamping dies in injection moulding machines, machines and installations. Preferably for use on the press ram.

### Description

The wedge clamp consists of a hydraulic block cylinder and a piston guided in a housing. The clamping bolt is provided with 20° bevel to clamp on the tapered clamping surface of the mould/die.

Based on the internal design of the wedge clamp and the 20° bevel of the clamping bolt, the system is providing internal friction. This patented design has a form-fit safety step in the form of a lug at the clamping bolt, which has the same shape as the adapter on the mould/die clamping edge. In the case of pressure drop (machine failure or down time) the upper mould/die lowers to the safety step onto the safety lug and is safely held by form fit. The clamping bolt can not be returned to the unclamping position and the upper mould/die is safely held.

### Retrofitting to wedge clamping

Retrofitting of already available moulds/dies to wedge clamping with form-fit safety step, can be made with adapter plates that are available as accessories (see page 3).

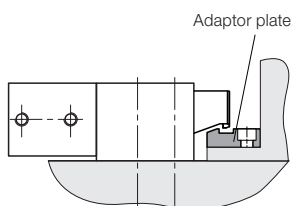

### Important notes

The greasing intervals (high temperature grease) should be adapted to the existing operating conditions. Please note that greasing of the wedge bolt should only be made with the elements being retracted.

The clamping elements must be protected against dirt, scale, swarf, coolant, etc. by means of a suitable covering.

Moulds or dies clamped by means of wedge clamps are subject to side loads that may be strong enough to displace them. Thus, positioning is required to absorb the side loads. Therefore, location pins or suitable limit stops should be provided to keep the moulds and dies in their correct position.

When using wedge clamps on the press ram, it is recommended that multiple-circuit hydraulic supply of the clamping elements and pilot-controlled check valves are used for securing hydraulic clamping.

### Circuit diagram

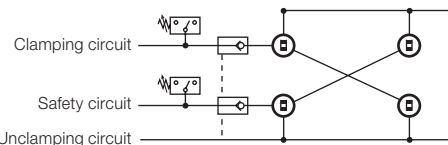

For safety reasons and in the sense of the machine tool guide lines ML2006/42/ EC the hydraulic pressure must be maintained.

When upper moulds/dies are clamped by wedge clamps, they must be secured mechanically when maintenance work is carried out.

### Versions

- with position monitoring at the side  
max. temperature: 100 °C

### Position monitoring

The integrated position monitoring is coupled to the clamping bolt in a very space-saving way at the side and signals:

1. Clamping bolt in unclamping position
2. Clamping bolt in clamping position
3. Error message when overrunning the clamping position

### Clamping force

This is the force the clamping element applies to the mould or die. The mould or die is clamped on the fixture plate by means of this force. The external forces acting on mould or die (e.g. ejecting force or die cushion force) shall not exceed the totality of the elements' clamping force.

### Maximum admissible operating force

This is the force that can be absorbed by the clamping element and the fastener (screws). It must be ensured that in cases of emergency, e.g. workpiece jammed in mould or die, the sum total of the elements' operating forces is not exceeded.

# Wedge clamps

## with form-fit safety step and position monitoring

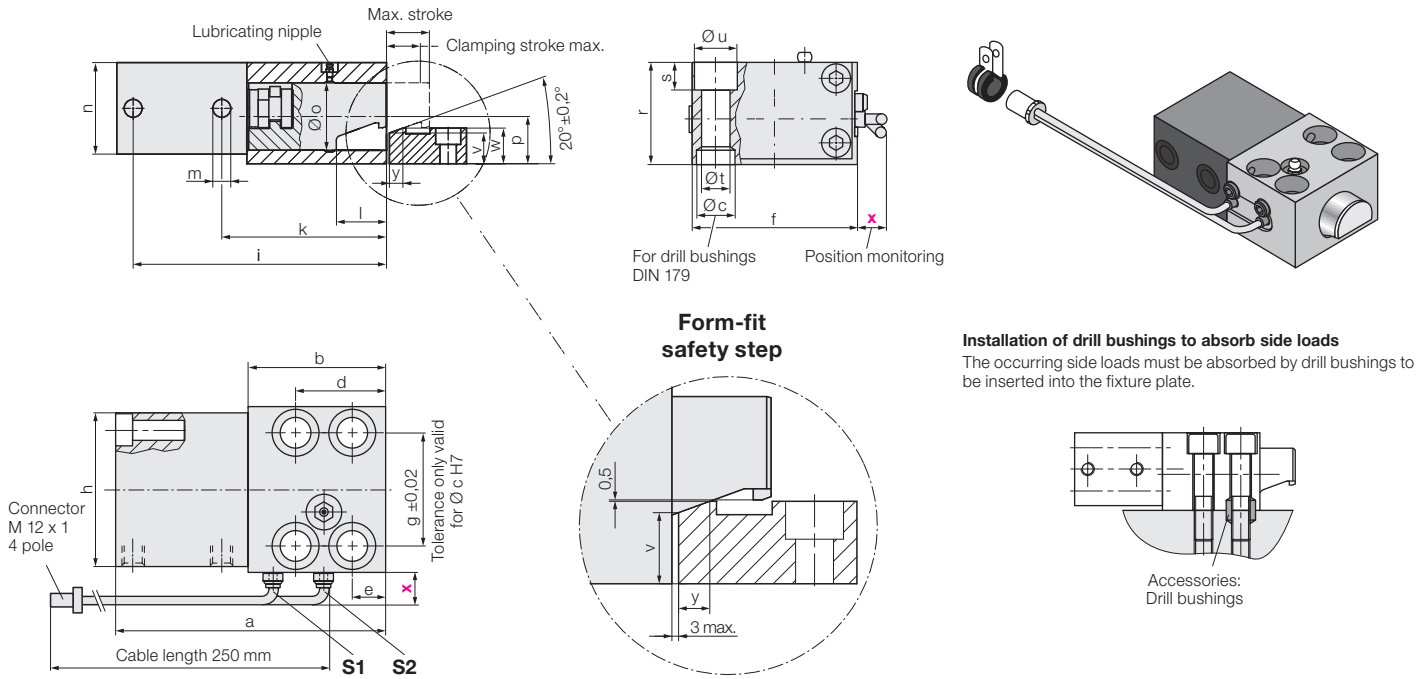

### Technical data

Temperature resistance up to 100 °C

Clamping force max.	[kN]	50	100	160	250	400
Max. admissible operating force						
Screw DIN 912 8.8	[kN]	65	130	210	320	520
<b>Max. operating pressure</b>	<b>[bar]</b>	<b>275</b>	<b>350</b>	<b>350</b>	<b>350</b>	<b>350</b>
Cylinder Ø	[mm]	40	50	63	80	100
Max. stroke	[mm]	50	50	63	50	80
Clamping stroke (from/to)	[mm]	40 – 44	40 – 44	44 – 48	45 – 49	66 – 70
Max. oil consumption	[mm]	63	98	196	251	628
a	[mm]	207	235	280	295	380
b	[mm]	103	120	145	160	210
Ø c H7 x depth	[mm]	26/9	30/11	35/11	48/13	55/16
d	[mm]	46	58	75	78	95
e	[mm]	16	20	25	26	32
f	[mm]	95	120	150	200	240
g	[mm]	65	85	106	140	180
h	[mm]	85	100	125	160	200
i	[mm]	196	222	263	274	355
k	[mm]	127	147	171	194	245
l	[mm]	45	45	52	52	75
m		G 1/4	G 1/4	G 1/2	G 1/2	G 1/2
n	[mm]	63	75	95	120	150
Ø o	[mm]	40	55	70	80	100
p	[mm]	28	37	49	55	75
r	[mm]	65	80	105	125	160
s	[mm]	18	20	26	32	38
Ø t	[mm]	17	21	26	33	39
Ø u	[mm]	26	32	40	48	57
v	[mm]	14.9	22.8	31.9	34.5	46.9
w	[mm]	20	29	37	39.6	55.6
x Position monitoring	[mm]	3	3	3	3	3
y	[mm]	14	14	14	14	24
Screw DIN 912-8.8 (4 off)		M16	M20	M24	M30	M36
Tightening torque	[Nm]	210	410	710	1450	2520
Weight	[kg]	8	13.3	25.6	43.7	93.2
<b>Part no. (including proximity switch)</b>		<b>824046000</b>	<b>824056000</b>	<b>824066000</b>	<b>824076000</b>	<b>824086000</b>

### Accessories

Drill bushings DIN 179	[mm]	17 x 16	21 x 20	26 x 20	32 x 25	38 x 30
<b>Part no.</b>		<b>3300287</b>	<b>3300288</b>	<b>3300289</b>	<b>3300420</b>	<b>3300430</b>

**Description**

The proximity switches are installed in the guide housing. They are activated by means of the wedge bolt. The positions of the bolt in off-position or in clamping position are displayed.

**S1:** Clamping bolt in unclamping position

**S2:** Clamping bolt in clamping position

**S2 is overrun:** Clamping bolt in final position (message for no mould/die available or mould/die not clamped)

Special versions with signal up to final bolt position are available on request.

**Connecting cable with screw coupling**

Cable length 5 m **Part no. 5700013**

Cable length 10 m **Part no. 5700014**

**Pin assignment 4-pole**

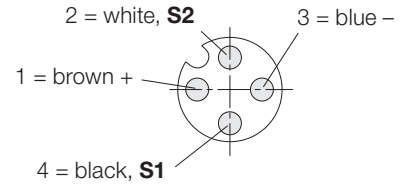

**Accessories**

**Adaptor plates**

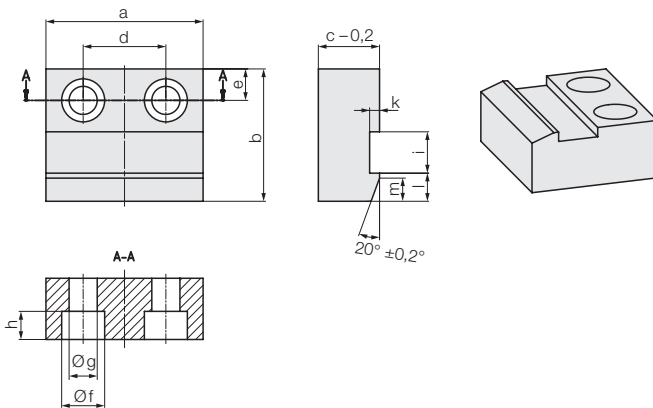

for wedge clamp		824046000	824056000	824066000	824076000	824086000
a	[mm]	50	80	95	105	130
b	[mm]	55	70	80	80	105
c	[mm]	20	29	37	39.6	55.6
d	[mm]	30	40	50	60	70
e	[mm]	9	16	19	19	20.5
Øf	[mm]	15	20	26	26	26
Øg	[mm]	9	13.5	17	17	17
h	[mm]	8.6	12.6	17	17	17
i	[mm]	20	21	25	27	34
k	[mm]	5	5	6	6	8
l	[mm]	17	17	17	17	30
m	[mm]	14	14	14	14	24
<b>Part no.</b>		<b>5 10280073</b>	<b>5 10280074</b>	<b>5 10280065</b>	<b>5 10280066</b>	<b>5 10280067</b>

**Application example**

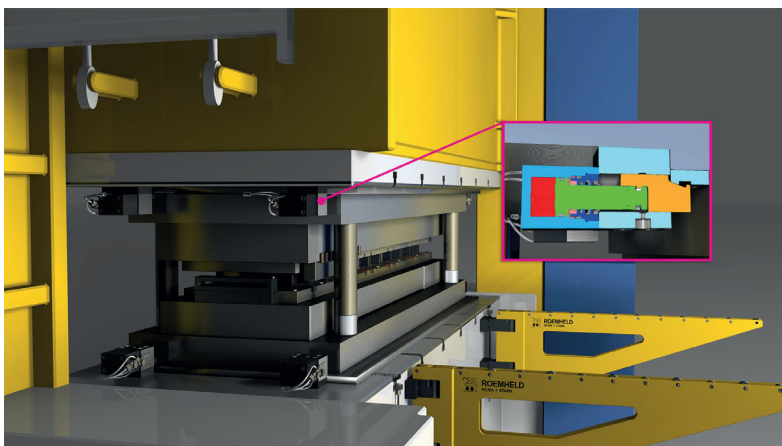

Wedge clamp with form-fit safety step in the press ram