

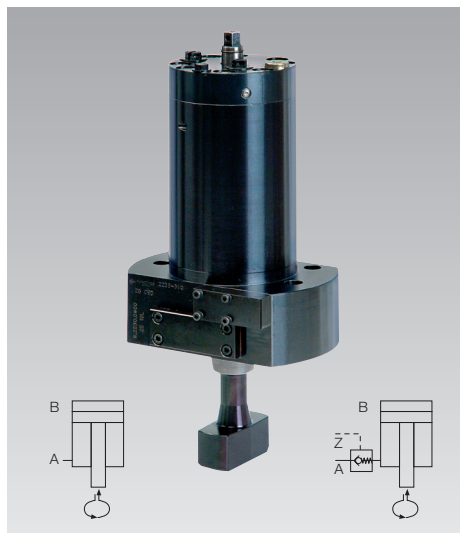

**Swing Sink Clamps**

double acting for exterior clamping, with 90° swing angle  
max. operating pressure 400 bar



**Advantages**

- Suitable for retrofitting
- Ideal force transmission
- Compact design
- High operating safety by position monitoring, manual emergency operation and overload protection
- Suitable for large clamping edge tolerances (±1.5 mm)
- Optimum utilisation of bed and ram surfaces so there are no parts protruding when inserting the die
- Clamping at difficultly accessible points
- Tie rod lengths up to 2000 mm

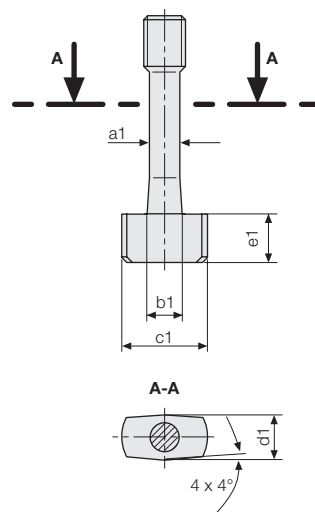

**Application**

Swing sink clamps can directly be mounted to the press bed or ram. They are particularly suitable where space is limited. Temperature range up to max. 70 °C

**Description**

The piston is guided by a control bolt so that during the stroke movement a rotation of 45° is effected. For clamping, the tie rod is rotated by 90° from the unclamping position and pulled against the clamping surface through the existing clamping slots.

Monitoring of the unclamping, change-over and clamping positions by inductive proximity switches. The swing mechanism is protected by a spring-loaded overload protection and equipped with manual emergency operation.

**Dimensions of tie rod**

Swing sink clamp		2235XXX				2237XXX		
F1 clamping slot in the die	[mm]	32	40	45	50	45	50	60
a1	[mm]	22	22	22	22	32	32	32
b1	[mm]	28	28	28	28	40	40	40
c1	[mm]	54	62	67	72	77	82	92
d1	[mm]	28	28	28	28	40	40	40
e1	[mm]	30	30	30	30	37	37	37

Please specify in your order the dimensions:  
**A** (ram plate), **B** (die clamping edge thickness) and **F1** (clamping slot)

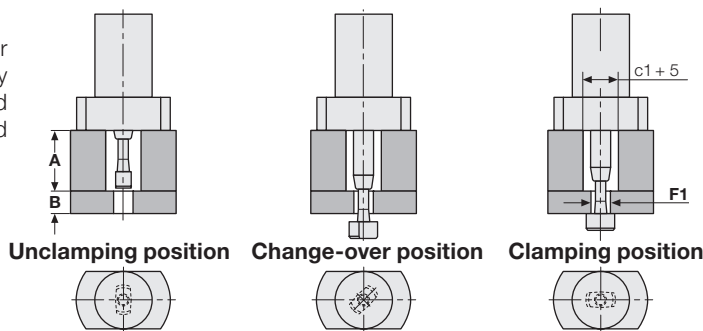

# Technical data Dimensions

## Technical data

Max. operating pressure 400 bar

Clamping force at 400 bar	[kN]	104	216
100 bar	[kN]	26	54
Piston $\varnothing e$	[mm]	70	100
Rod $\varnothing d$	[mm]	40	56
Max. clamping edge height	[mm]	68	68
Swing stroke i	[mm]	15	23
Clamping and sink stroke h	[mm]	105	112
Oil volume clamping	[cm <sup>3</sup> ]	514	1211
Oil volume unclamping	[cm <sup>3</sup> ]	388	948
Max. flow rate	[cm <sup>3</sup> /s]	50	120
a	[mm]	170	212
b	[mm]	240	270
c	[mm]	104	146
f	[mm]	M27 x 1.5	M36 x 2
g	[mm]	G 3/8	G 1/2
j	[mm]	G 1/4	G 1/4
k	[mm]	42	55
l	[mm]	50	71
m	[mm]	38	57
n	[mm]	25	34
o	[mm]	39.8	62
p	[mm]	14	18
q	[mm]	17.3	27.6
r	[mm]	62.5	84
s	[mm]	104	146
t	[mm]	10	23
u	[mm]	40	50
v	[mm]	60	65
w	[mm]	16.7	27.6
x	[mm]	22.6	22.6
y	[mm]	4.2	0
z	[mm]	24	31
SW	[mm]	14	22
Weight	[kg]	16.5	35
<b>without check valve</b>	<b>Part no.</b>	<b>2235310</b>	<b>2237310</b>
<b>with check valve</b>	<b>Part no.</b>	<b>2235410</b>	<b>2237410</b>

Further sizes and special versions are available on request

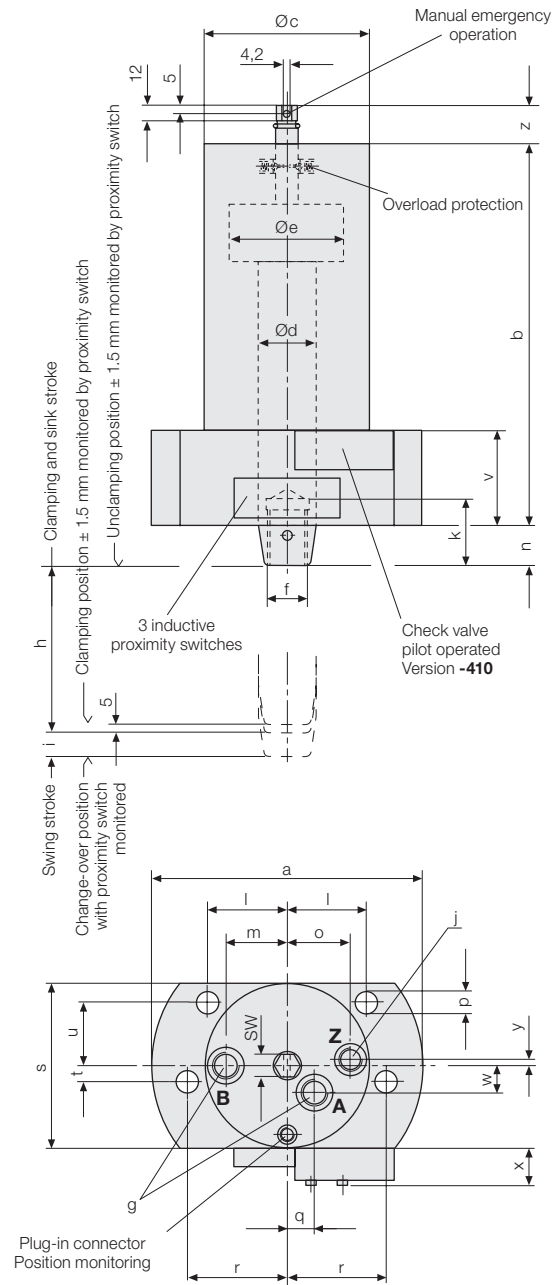

# Functional description

## Functional diagrams

### Functional description

The piston of the double-acting swing sink clamp is guided by a guide pin in such a manner that during part of the stroke a 45° rotation is carried out just before reaching and just after leaving the piston upper end position. The rotation is always anti-clockwise, no matter whether the piston extends or retracts.

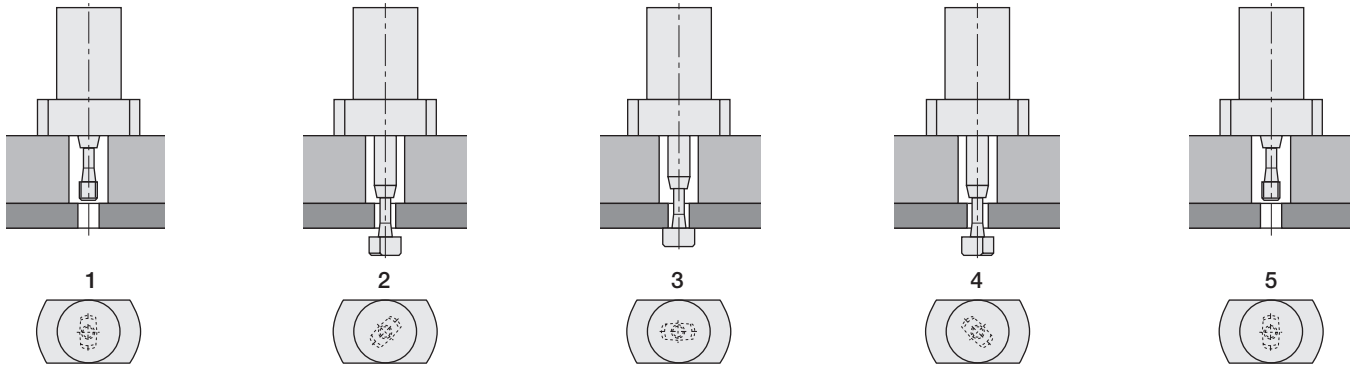

#### 1. Unclamping position

The piston is completely retracted. This permits an easy die change, as no parts project over the bed or ram level.

#### 2. Change-over position

For clamping, pressure is applied to the piston side B. The tie rod passes through the slot of the clamping point and is then rotated by 45°.

#### 3. Clamping position

Pressure is applied to the piston rod side A. The tie rod makes a further 45° rotation and is now transversely above the clamping point. **The die is clamped.** The proximity switch 2S3 monitors this position.

#### 4. Change-over position for unclamping

Pressure is applied to the piston side B. The tie rod is extended and then again rotated by 45°. Proximity switch 2S2 monitors this position.

#### 5. Unclamping position

Pressure is applied to the piston rod side A. The tie rod makes a further 45° rotation and passes through the slot of the clamping point as far as the end position. Proximity switch 2S1 monitors this position. **The die is unclamped.**

### Functional diagrams

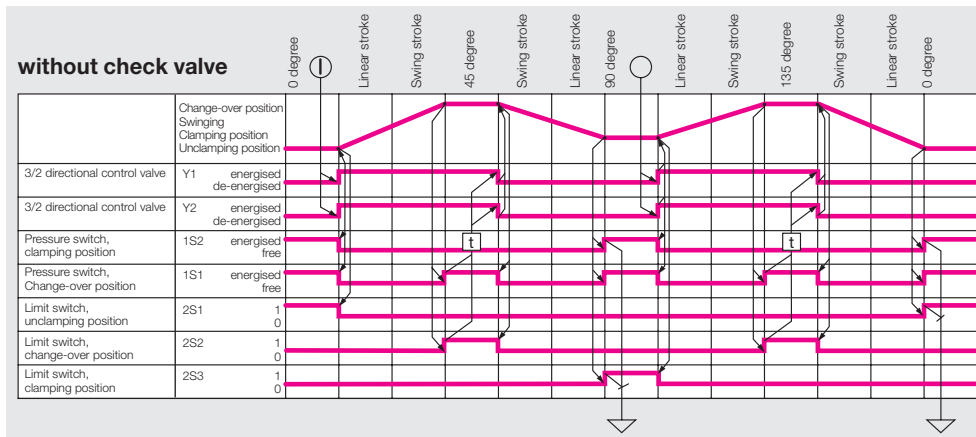

### Hydraulic circuit diagram without check valve

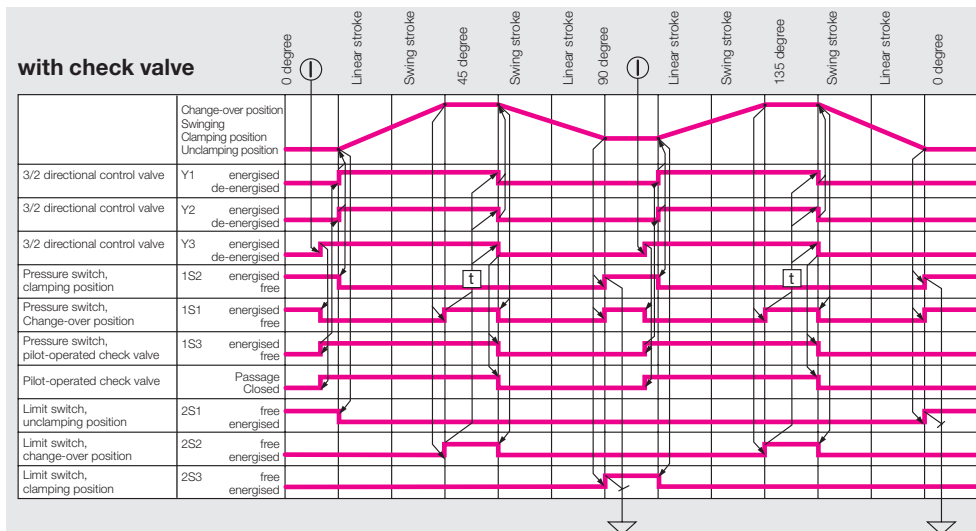
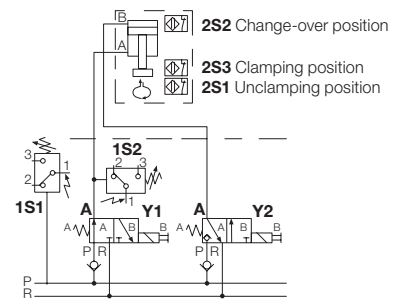

### Hydraulic circuit diagram with check valve

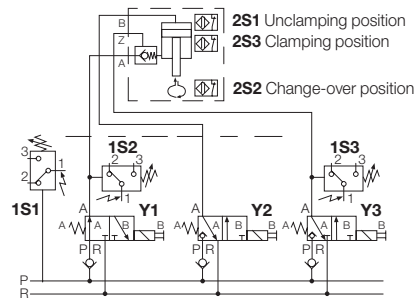

# Installation

## Hydraulic installation

Read the operating manual before starting up. Adjust the flow rate of the power unit so that clamping and unclamping cycles between 10 and 30 seconds are obtained. In order to prevent the swing mechanism from premature wear, the dynamic pressure at port B should not exceed 50 bar while the tie rods retract through the slot. Swing sink clamps which are grouped together

should be connected to distribution boards, in order to avoid series connection. Use pipes with larger diameter for connection to the power unit. If in doubt, please send the installation plan to be reviewed. Provide a pressure gauge connection in every hydraulic circuit for adjustment and to check operating data. Other parameters and recommendations for hy-

draulic installation of die clamping systems are given in chapter no. 1 "General information".

### Important note!

The full stroke of the piston must be realised, otherwise the swing mechanism may be damaged.

## Pin assignment for three-wire proximity switches

Supply voltage	10 – 30 V DC
Constant current	≤ 100 mA
Type	inductive, break contact pnp

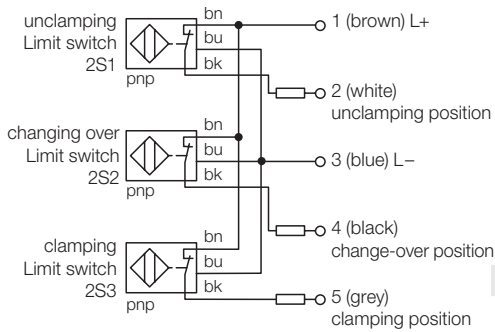

## Accessories

### 5-pole connecting cable with screw coupling

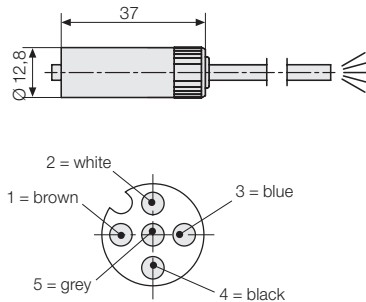

Cable length 5 m **Part no. 5700013**  
 Cable length 10 m **Part no. 5700014**

## Accessories

### Distribution board with LED display for the connection of 4 clamps

Display of the unclamping, change-over and clamping position of each clamping element via LED display

### Delivery

- 1 distribution board
- 4 5-pole coupling plug
- 1 16-pole coupling plug

### Part no. 5700015

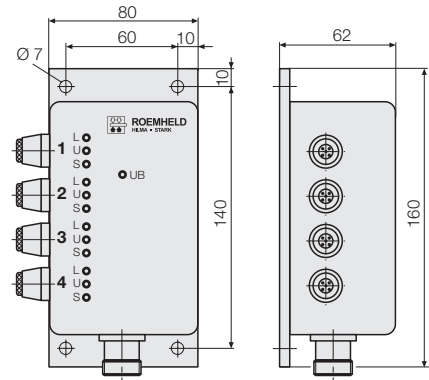

### Pin assignment of output plug:

Pin 1 = L+	Pin 9 = 3L
Pin 2 = L-	Pin 10 = 3U
Pin 3 = 1L	Pin 11 = 3S
Pin 4 = 1U	Pin 12 = 4L
Pin 5 = 1S	Pin 13 = 4U
Pin 6 = 2L	Pin 14 = 4S
Pin 7 = 2U	Pin 15 = free
Pin 8 = 2S	Pin 16 = free

**L = unclamping position**  
**U = change-over position**  
**S = clamping position**