

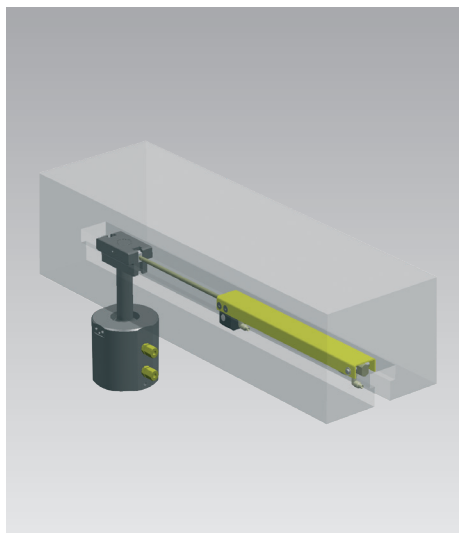

Rapid Clamping System with Pneumatic Cylinder

“Pneumatic travelling clamp”, max. operating pressure 10 bar with single and double-acting clamping elements



Advantages

- Robust solution for short distances of travel
- Easy installation using standard clamping elements
- For fixing, no modification to the press ram is required
- Rapid adaptation to various die sizes

Possible clamping elements:

Hollow piston cylinder, double acting with a max. clamping force of 115 kN

Hollow piston cylinder, single acting with a max. clamping force of 104 kN

Locking cylinder, double acting with a max. clamping force of 100 kN

Spring clamping cylinder, single acting with a max. clamping force of 100 kN

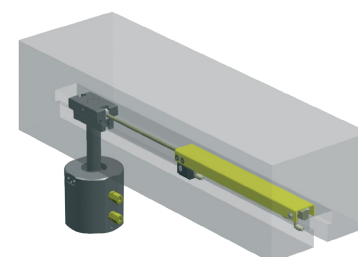

Sliding clamp, single acting

with a max. clamping force of 78 kN

Application

The rapid clamping systems “Pneumatic travelling clamp” are used for automatic displacement of standard clamping systems with a pneumatic cylinder for short distances of travel.

Description

The pneumatic positioning drive fits completely into a T-slot as per DIN 650 with a slot width of 28 mm, therefore the positioning cylinder can be positioned upstream or downstream of the clamping element. The positioning drive is fastened in the T-slot using a wedge lock without the need to modify the press ram.

Query of the unclamping and clamping positions is carried out using inductive magnetic sensors on the pneumatic cylinder.

Delivery

- Clamping element
- Pneumatic positioning drive unit including screw fittings for pneumatic connection and position control on the cylinder.
- High-pressure hose and screw fittings for hydraulic connections on the clamping element

Technical data

Operating pressure pneumatic	[bar]	min. 6 (max. 10)
Travelling distance	[mm]	200
Temperature range	[°C]	up to 70
Weight of the clamping element:		
at 6 bar	[kg]	max. 8.5
at 10 bar	[kg]	max. 14

Options

- Parking station (for the unclamping position outside of the press ram)
- Travelling distance up to 400 mm
- Reed contacts instead of inductive magnetic sensors
- Pneumatic flow control valves for adjusting the travelling speed

Other optional extras including adaptation are available upon request.

Angular clamp, single acting

with a max. clamping force of 66 kN

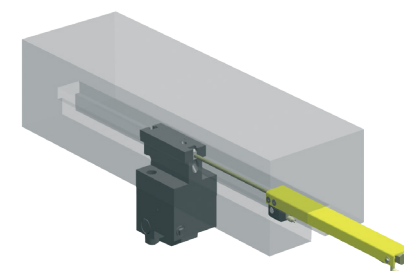

Application example

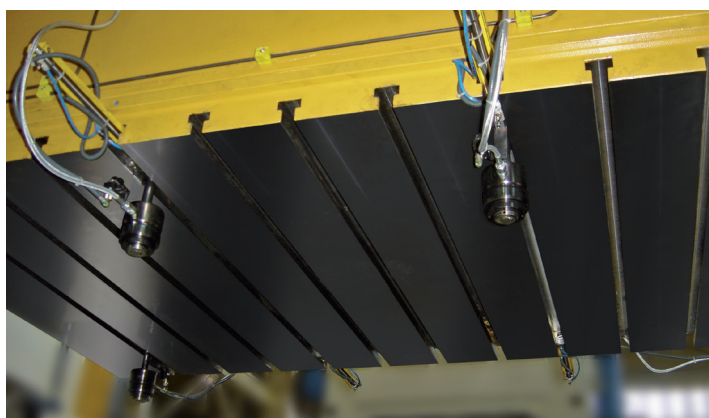

Rapid clamping system with pneumatic cylinder

Dimensions Installation variants

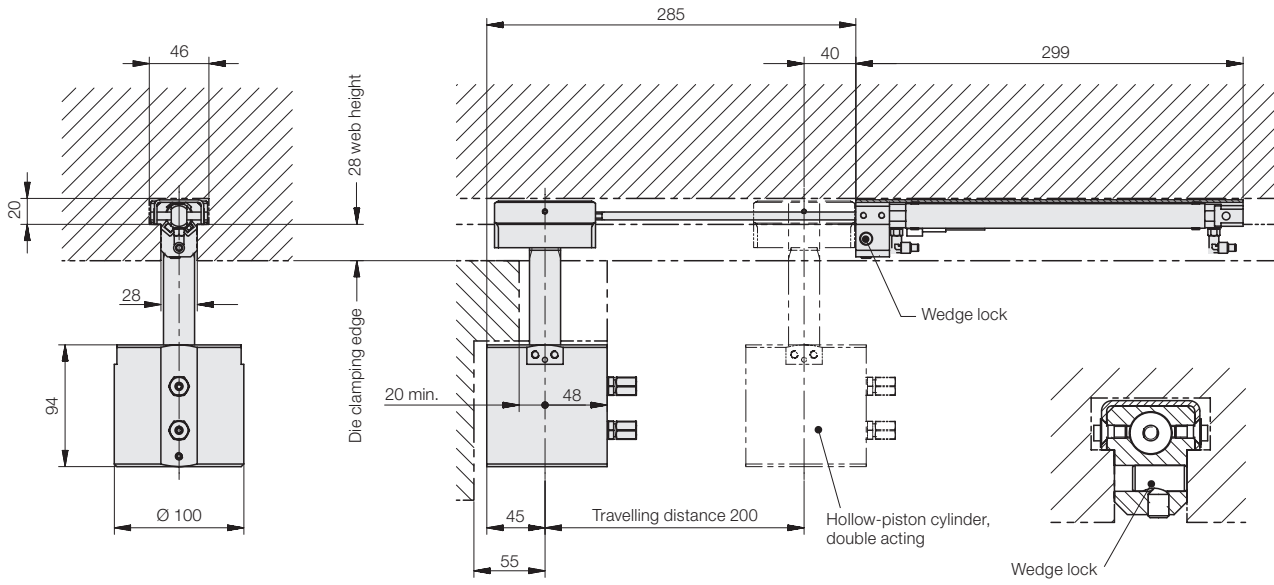

Installation variants

