

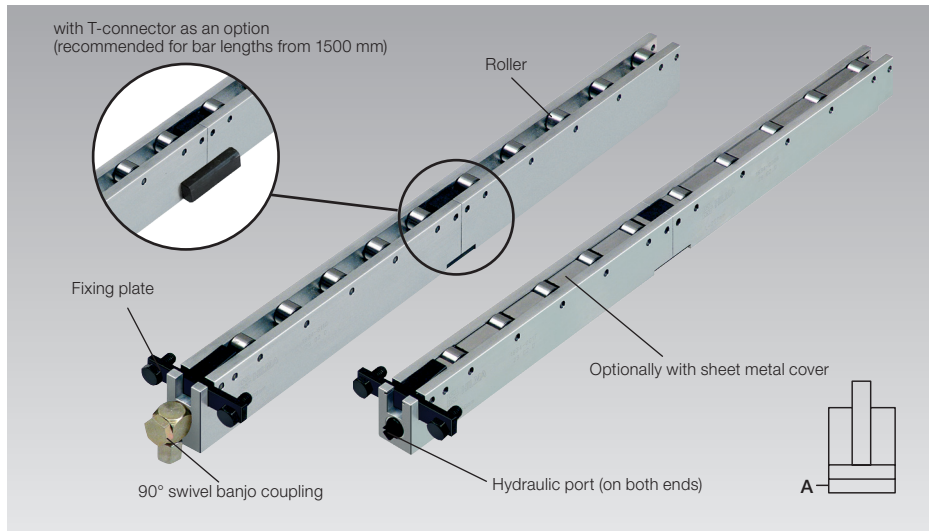

**Roller Bars, Hydraulic**  
with lifting of the bar  
max. load 160 kN/m, max. operating pressure 400 bar



**Advantages**

- Easy and safe die change
- Hydraulic lifting of the complete bar
- Very high loads
- Lengths up to 2500 mm in 250 mm long segments
- The hydraulic supply is protected inside the slot base
- Easy cleaning of the bars and rollers by open design
- Low weight (version in aluminium)

**Application**

- In T-slots and rectangular slots of the press bed for easy die change without any problems
- Die change streamlining

**Delivery**

- Roller bar
- Fixing plate
- 90° swivel banjo coupling

**Description**

Roller bar with hydraulic lifting of the complete bar for heavy loads and linear movement of the dies.  
On the underside of the roller bar, lifting pistons are provided. Pressure is applied to these pistons using hydraulic pressure generators, which lift then the complete roller bar. The die positioned on the roller bars is not in contact with the table top and can be easily moved linearly and positioned.

**T-slot tolerances as per DIN 650**

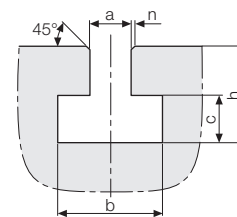

a	b	c	h min.	h max.	n max.
<b>22 H12</b>	37 <sup>+3</sup>	16 <sup>+2</sup>	<b>38</b>	45	1.6
<b>28 H12</b>	46 <sup>+4</sup>	20 <sup>+2</sup>	<b>48</b>	56	1.6
<b>36 H12</b>	56 <sup>+4</sup>	25 <sup>+3</sup>	<b>61</b>	71	2.5

Dimensions in mm  
h<sub>min.</sub> = minimum dimension as per DIN 650

The height of the roller bars is designed for the dimension h<sub>min.</sub> of the slot dimension.

**Technical data**

Max. operating pressure	[bar]	400
Max. load	[kN/m]	160
Roller spacing	[mm]	50
Material of the bar		aluminium (steel on request)
Fixing of the bar		fixing plate or positioning pin
Standard lengths	[mm]	250 ... 2500
		consisting of 250 mm long segments
Intermediate lengths	[mm]	shortening of the segments in 50 mm increments

**Application example**

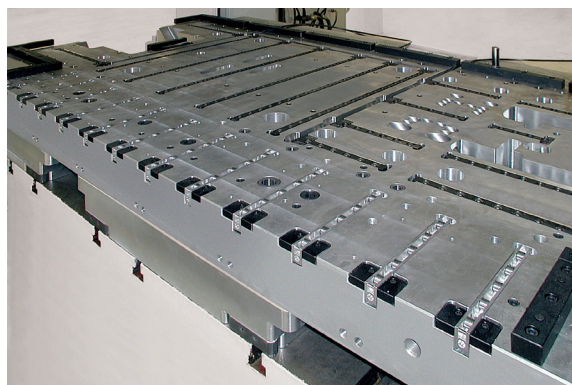

Roller bars with hydraulic lifting



Clamping bars installed in press bed and ram. Easy feeding of dies by die changing consoles and hydraulic ball bars installed in the T-slots of the press bed.

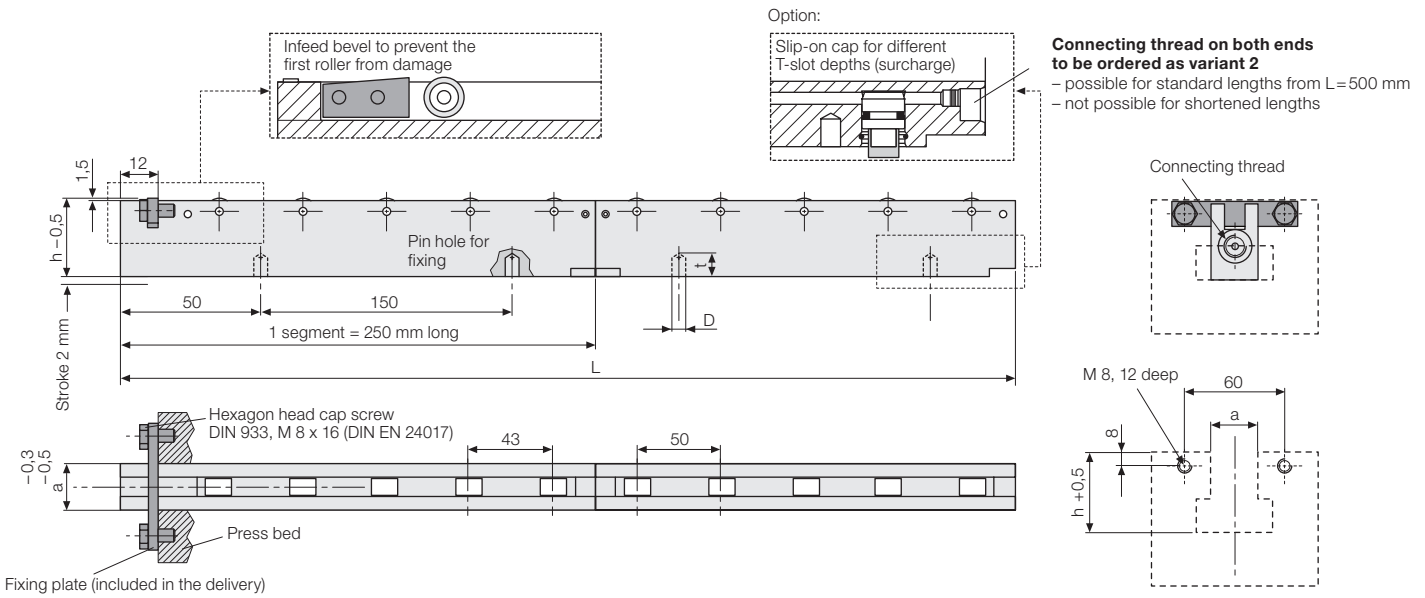

**Technical data**

Max. temperature 100 °C

Slot width (a)	[mm]	22	28	36
Slot depth (h)	[mm]	38	48	61
Slot depth max. (h)	[mm]	45	56	71
Load/roller	[kN]	6.0	6.4	8.0
Number of rollers/segment (= 250 mm)		5	5	5
Number of pistons/segment (= 250 mm)		5	4	5
Connecting thread		G 1/8	G 1/8	G 1/4
Max. operating pressure	[bar]	400	400	400
Roller Ø x width	[mm]	16 x 12	16 x 12	19 x 12
Stroke	[mm]	2	2	2
Oil volume/segment	[cm³]	1.54	1.60	2.00
D	[mm]	6.5	8.5	8.5
t	[mm]	9	12	12

Fixing plate and 90° swivel banjo coupling are included in the delivery.

**Accessories**

**Infeed support**

to protect the first rollers

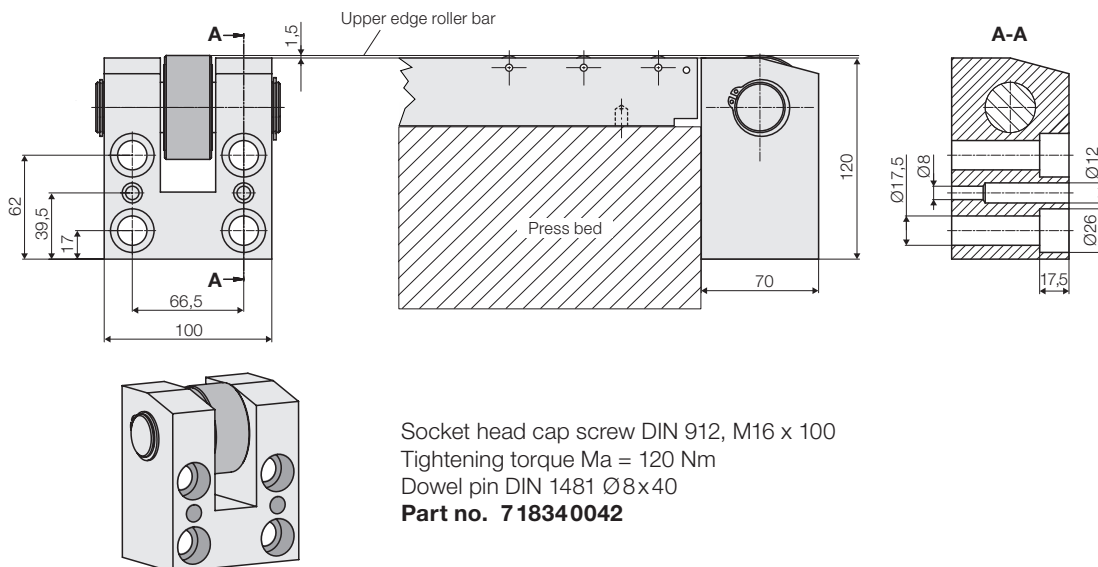

Dimensions in [mm]

**Standard lengths**

**Part no.**

**for slot width a = 22 mm**

Length (L) [mm]	Load [kN] at 400 bar	Part no.
250	30	<b>8 1834 5100</b>
500	60	<b>8 1834 5110</b>
750	90	<b>8 1834 5115</b>
1000	120	<b>8 1834 5120</b>
1250	150	<b>8 1834 5130</b>
1500	180	<b>8 1834 5140</b>
1750	210	<b>8 1834 5150</b>
2000	240	<b>8 1834 5160</b>
2250	270	<b>8 1834 5170</b>
2500	300	<b>8 1834 5180</b>

**for slot width a = 28 mm**

Length (L) [mm]	Load [kN] at 400 bar	Part no.
250	32	<b>8 1834 6100</b>
500	64	<b>8 1834 6110</b>
750	96	<b>8 1834 6115</b>
1000	128	<b>8 1834 6120</b>
1250	160	<b>8 1834 6130</b>
1500	192	<b>8 1834 6140</b>
1750	224	<b>8 1834 6150</b>
2000	256	<b>8 1834 6160</b>
2250	288	<b>8 1834 6170</b>
2500	320	<b>8 1834 6180</b>

**for slot width a = 36 mm**

Length (L) [mm]	Load [kN] at 400 bar	Part no.
250	40	<b>8 1834 7100</b>
500	80	<b>8 1834 7110</b>
750	120	<b>8 1834 7115</b>
1000	160	<b>8 1834 7120</b>
1250	200	<b>8 1834 7130</b>
1500	240	<b>8 1834 7140</b>
1750	280	<b>8 1834 7150</b>
2000	320	<b>8 1834 7160</b>
2250	360	<b>8 1834 7170</b>
2500	400	<b>8 1834 7180</b>

**Intermediate lengths**

Possible intermediate lengths: 300 to 2450 mm. Produced by shortening of the segments in 50 mm increments.

**Determination of the carrying force for intermediate lengths**

**for slot width a = 22 mm**

Shortening by [mm]	Carrying force reduction [kN]
50	6
100	12
150	18
200	24

**for slot width a = 28 mm**

Shortening by [mm]	Carrying force reduction [kN]
50	8
100	16
150	16
200	24

**for slot width a = 36 mm**

Shortening by [mm]	Carrying force reduction [kN]
50	8
100	16
150	24
200	32

**Examples for intermediate lengths of roller bar L = 500 mm**

**Part no.:**

Add the desired length "LXXX" in mm to the part number.

**for slot width a = 22 mm**

Length (L) [mm]	Load [kN] at 400 bar	Example
300	36	<b>8 1834 5110 L300</b>
350	42	<b>8 1834 5110 L350</b>
400	48	<b>8 1834 5110 L400</b>
450	54	<b>8 1834 5110 L450</b>

**for slot width a = 28 mm**

Length (L) [mm]	Load [kN] at 400 bar	Example
300	40	<b>8 1834 6110 L300</b>
350	48	<b>8 1834 6110 L350</b>
400	48	<b>8 1834 6110 L400</b>
450	56	<b>8 1834 6110 L450</b>

**for slot width a = 36 mm**

Length (L) [mm]	Load [kN] at 400 bar	Example
300	48	<b>8 1834 7 110 L300</b>
350	56	<b>8 1834 7 110 L350</b>
400	64	<b>8 1834 7 110 L400</b>
450	72	<b>8 1834 7 110 L450</b>

**Connecting thread on both ends: Variant "2"**

- possible for standard lengths from L=500 mm
- not possible for shortened lengths

**Part no.**

Add "-2" to the part no. of the roller bar.

**Example: 8 1834 5110-2**

**Special versions**

**Sheet metal cover**

The roller bars are also available with sheet metal cover between the rollers on request.

**T-connector**

For bar lengths from 1500 mm, it is recommended to equip the individual segments with T-connectors (see figure on page 1). Thus, the roller bars are reinforced and the dimensional stability is increased.

**Customised special versions**

Different heights, lengths, strokes, roller and piston number per segment, other customised versions as well as inch versions are available on request.

