

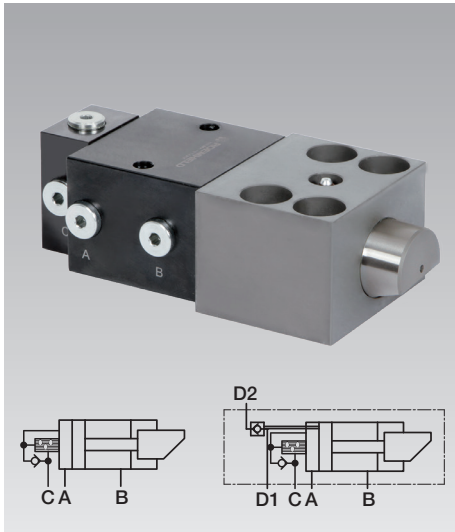

Wedge Clamps for Tapered Clamping Edge
double acting, max. clamping force 25 to 630 kN,
with sequence valve control for high temperature ranges



Advantages

- Optional safety step for the support of the upper die or mould half when the pressure drops
- Safe clamping of moulds/dies with tapered clamping edge at high temperatures
- Very sturdy design
- High safety standard
- Hydraulic position monitoring, without electrics
- High operational safety by hydraulic position monitoring and automatic motion sequence of the clamping bolt

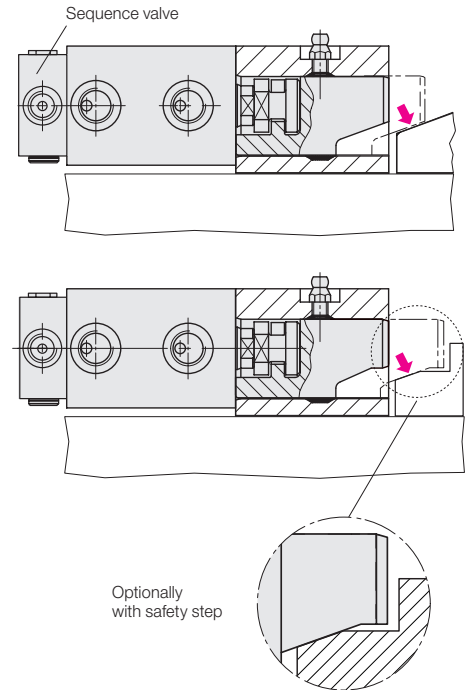

Application

Double-acting wedge clamp with optional safety step at the clamping bolt for clamping moulds or dies on a press bed or ram or in injection moulding machines, machines and installations.

Description

The wedge clamp consists of a hydraulic block cylinder and a piston guided in a housing. The clamping bolt is provided with 20° bevel to clamp on the tapered clamping surface of the die.

Based on the internal design of the wedge clamp and the 20° bevel of the clamping bolt, the system is providing internal friction.

Wedge clamps with hydraulic position monitoring for high temperatures. An additional valve block on the standard wedge clamp enables hydraulic control of the clamping position.

Only after the last wedge clamp has been clamped, the machine control is released by a pressure switch on the pressure generator.

Retrofitting to wedge clamping

Wedge clamping of existing moulds/dies is possible by retrofitting V-shaped inserts as shown below. Max. hardness 50 HRC

Hardened V-shaped insert

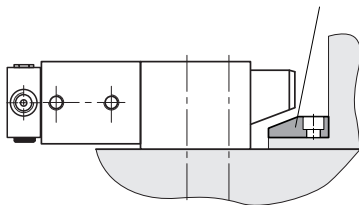

Optional safety step

The clamping bolt of this version has an additional support surface parallel to the clamping edge.

In the case of pressure drop (machine failure or down time) the upper mould/die can be lowered to the safety step and safely held.

Important notes

The greasing intervals (high temperature grease) should be adapted to the existing operating conditions. Please note that greasing of the wedge bolt should only be made with the elements being retracted.

The clamping elements must be protected against dirt, scale, swarf, coolant, etc. by means of a suitable covering.

Moulds or dies clamped by means of wedge clamps are subject to side loads that may be strong enough to displace them. Thus, positioning is required to absorb the side loads. Therefore, location pins or suitable limit stops should be provided to keep the moulds and dies in their correct position.

When using wedge clamps on the press ram, it is recommended that multiple-circuit hydraulic supply of the clamping elements and pilot-controlled check valves are used for securing hydraulic clamping.

Circuit diagram

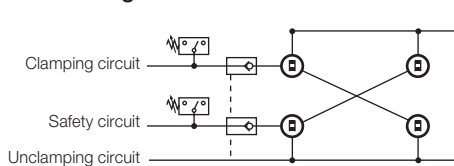

For safety reasons and in the sense of the machine tool guide lines ML2006/42/EC the hydraulic pressure must be maintained.

When upper moulds/dies are clamped by wedge clamps, they must be secured mechanically when maintenance work is carried out.

Versions

- with hydraulic position monitoring with sequence valve control to monitor the clamping position
max. temperature: 160 °C (300 °C on request)
- with hydraulic position monitoring with double sequence valve control to monitor the clamping and unclamping position
max. temperature: 160 °C (300 °C on request)

Clamping force

This is the force the clamping element applies to the mould or die. The mould or die is clamped on the fixture plate by means of this force. The external forces acting on mould or die (e.g. ejecting force or die cushion force) shall not exceed the totality of the elements' clamping force.

Maximum admissible operating force

This is the force that can be absorbed by the clamping element and the fastener (screws). It must be ensured that in cases of emergency, e.g. workpiece jammed in mould or die, the sum total of the elements' operating forces is not exceeded.

Wedge clamps

Sequence valve control to monitor the clamping position

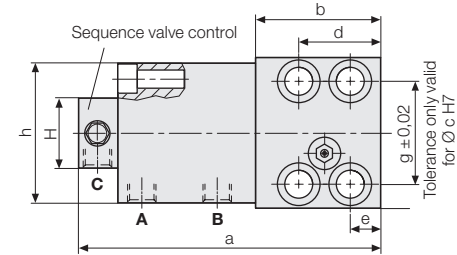
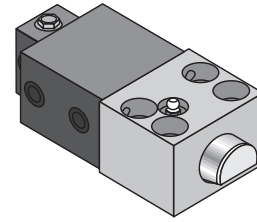
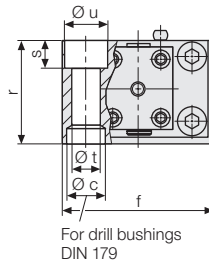
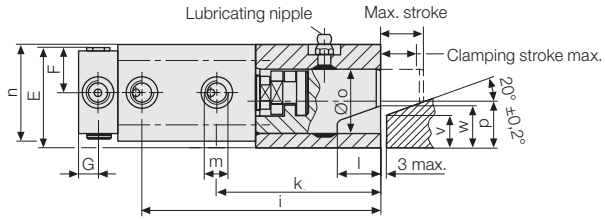

Installation of drill bushings to absorb side loads
The occurring side loads must be absorbed by drill bushings to be inserted into the fixture plate.

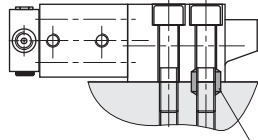

Accessories:
Drill bushings

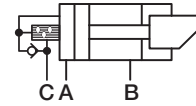

A = Hydraulic port clamping
B = Hydraulic port unclamping
C = Hydraulic port sequence valve

Technical data

Temperature resistance up to 160 °C

Clamping force max.	[kN]	25*	50	100	160	250	400	630
Max. admissible operating force								
Screw DIN 912 8.8	[kN]	35	65	130	210	320	520	820
Max. operating pressure	[bar]	350	275	350	350	350	350	350
Cylinder Ø	[mm]	25	40	50	63	80	100	125
Max. stroke	[mm]	20	25	25	30	32	40	40
Clamping stroke (from/to)	[mm]	15 – 18	18 – 22	19 – 22	23 – 27	24 – 29	30 – 36	30 – 36
Max. oil consumption	[mm]	10	31	49	94	161	314	491
Sequence valve control	[mm]	12	14	14	17	17	22	22
a	[mm]	152	187	220	262	302	345	410
b	[mm]	58	78	100	125	150	180	225
Ø c H7 x depth	[mm]	18/7	26/9	30/11	35/11	48/13	55/16	62/16
d	[mm]	38	46	58	75	78	95	108
e	[mm]	14	16	20	25	26	32	38
f	[mm]	70	95	120	150	200	240	280
g	[mm]	48	65	85	106	140	180	210
h	[mm]	65	85	100	125	160	200	230
i	[mm]	111	146	177	210	246	285	344
k	[mm]	76	102	127	151	184	215	272
l	[mm]	20	25	26	32	40	45	50
m		G 1/4	G 1/4	G 1/4	G 1/2	G 1/2	G 1/2	G 1/2
n	[mm]	45	63	75	95	120	150	180
Ø o	[mm]	30	40	55	70	80	100	125
p	[mm]	21.5	28	37	49	55	75	85
r	[mm]	48	65	80	105	125	160	190
s	[mm]	13	18	20	26	32	38	44
Ø t	[mm]	13	17	21	26	33	39	45
Ø u	[mm]	20	26	32	40	48	57	66
v	[mm]	15	18	25	30	30	50	60
w	[mm]	19.5	23.5	30.5	37	38	60	70
E	[mm]	48	68	75	89	96.5	116.5	131.5
F	[mm]	22.5	31.5	37.5	47.5	60	75	90
G	[mm]	16	14	14	16	16	16	16
H	[mm]	64	48	48	90	90	90	90
Screw DIN 912-8.8 (4 off)		M 12	M 16	M 20	M 24	M 30	M 36	M 42
Tightening torque	[Nm]	86	210	410	710	1450	2520	4050
Weight	[kg]	3.0	6.5	11.4	21.7	41	74.7	126
Part no.		824032500	824042500	824052500	824062500	824072500	824082500	824092500

Accessories

Drill bushings DIN 179	[mm]	12 x 12	17 x 16	21 x 20	26 x 20	32 x 25	38 x 30	44 x 30
Part no.		3300285	3300287	3300288	3300289	3300420	3300430	3300440

* lubricating nipples of the version with a clamping force of 25 kN are offset by 9.5 mm and protrude by 5 mm

Wedge clamps

Sequence valve control to monitor the clamping position and safety step

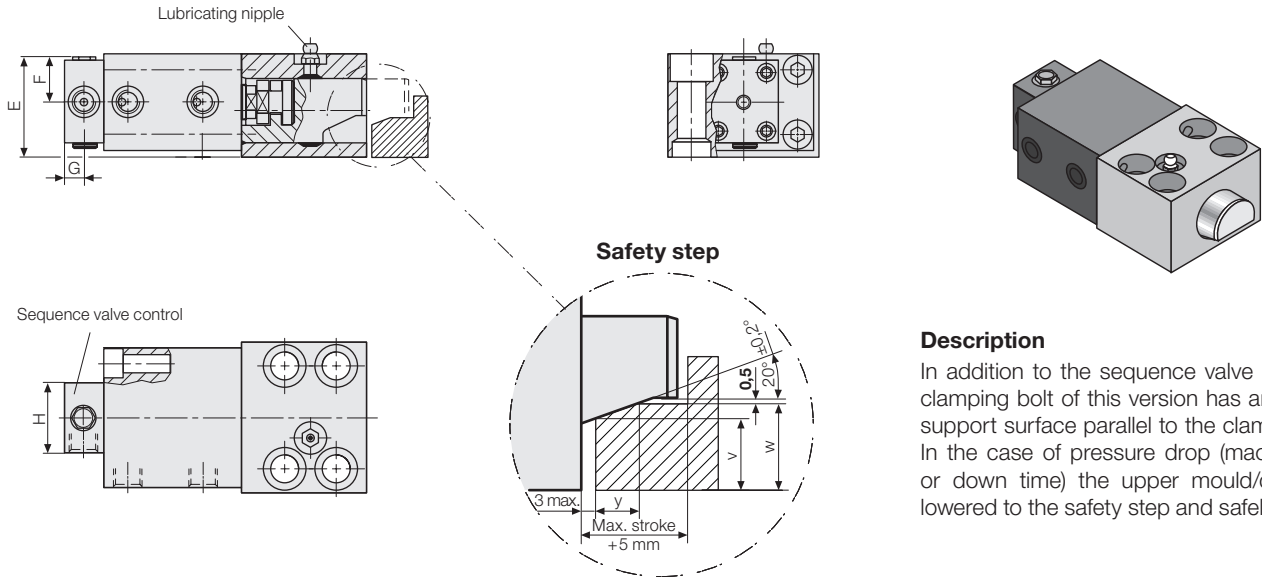

Description

In addition to the sequence valve control, the clamping bolt of this version has an additional support surface parallel to the clamping edge. In the case of pressure drop (machine failure or down time) the upper mould/die can be lowered to the safety step and safely held.

Technical data

Temperature resistance up to 160 °C

Clamping force max.	[kN]	25*	50	100	160	250	400	630
w	[mm]	17.5	21.2	28.2	34.7	35.3	57.3	67.3
y	[mm]	7.0	8.7	8.7	12.9	14.6	20.1	20.1
Part no.		824033500	824043500	824053500	824063500	824073500	824083500	824093500

* lubricating nipples of the version with a clamping force of 25 kN are offset by 9.5 mm and protrude by 5 mm

** high temperatures up to 300 °C on request.

Wedge clamps

Double sequence valve control to monitor the clamping and unclamping position

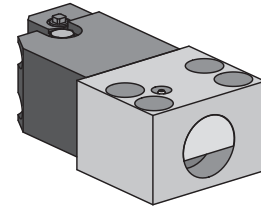
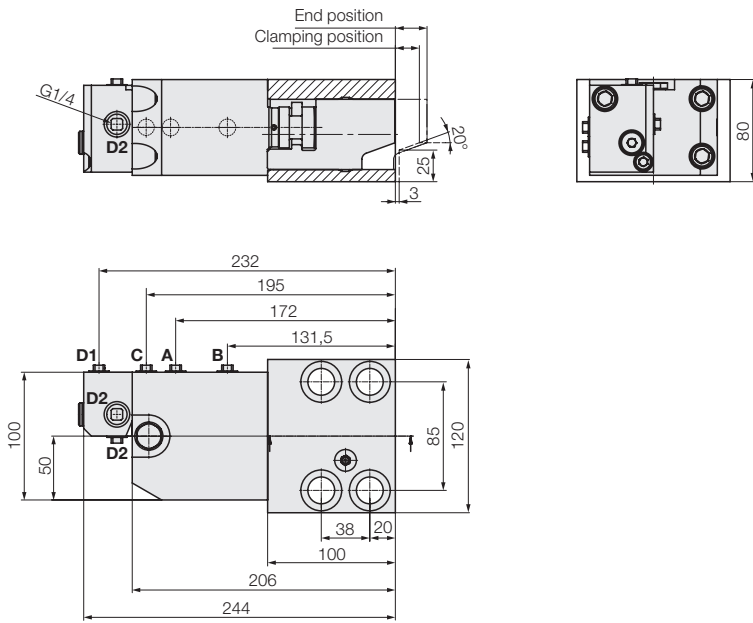

Description

The wedge clamp enables the hydraulic control of the clamping and unclamping position. Only after the last wedge clamp has been clamped, the machine control is released by a pressure switch on the pressure generator.

Version with safety step

The version with double sequence valve control is also available with safety step at the clamping bolt on request (description see page 3).

Technical data

Temperature resistance of up to 160°C (higher temperatures on request)

Clamping force max.	[kN]	100*
Max. admissible operating force screws DIN 912 8.8	[kN]	130
Max. operating pressure	[bar]	350
Cylinder Ø	[mm]	50
Max. stroke	[mm]	25
Clamping stroke (from/to)	[mm]	19 – 22
Sequence valve control	[mm]	13
Screw DIN 912-8.8 (4 off)		M 20
Tightening torque	[Nm]	410
Weight	[kg]	12.5

* Other sizes on request

Element in clamping position

Port A pressurized, bolt moves to the clamping position. The oil displaced by the piston movement escapes at port B. The sequence valve opens after approx. 50% of the total stroke and oil escapes with full pressure at port C.

Element in unclamping position

Pressurise port D1, port D2 must remain free of oil. Pressurise port B. The oil displaced by the piston movement escapes at port A and C. The second sequence valve will be opened maximally 2 mm before the end position of the bolt and oil escapes with full pressure at port D2.

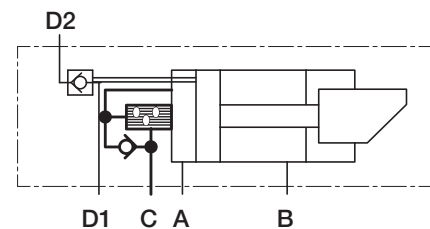

- A** = Clamping
- B** = Unclamping
- C** = To the following element
- D** = Sequence released to the following element