



High-Pressure Spindles, Mechanical
with integrated wedge system
clamping force 40 to 140 kN



Figure: Section of high-pressure spindle

Advantages

- Easy to retrofit
- Temperature resistance up to 250 °C
- Compact design allows for multiple clamping
- High clamping force with low tightening torque
- Self-locking due to patented wedge system
- Individual use

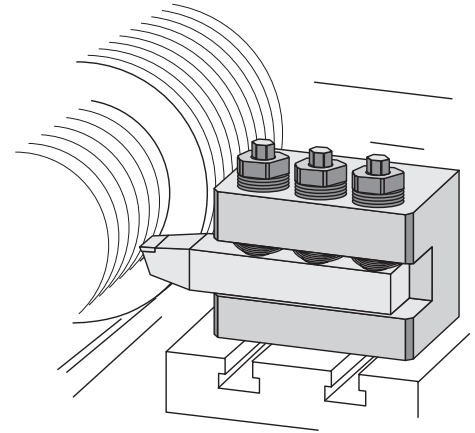

Application

- In bars and blocks
- Clamping and locking of workpieces and dies
- When the available space is limited
- In presses, punching machines and machine tools

Description

Following manual positioning of the high-pressure spindle against the clamping edge, the drive spindle is operated by turning the hexagon nut SW1. Thus, the clamping force is transmitted in axial direction to the clamping point by the wedge system.

The required clamping force is achieved by selecting the appropriate torque on the torque wrench (see force torque diagram). For unclamping, proceed in the reverse order.

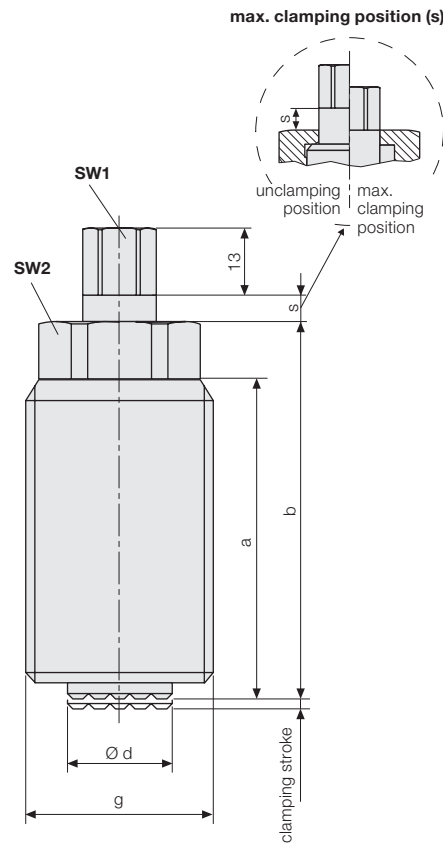

Clamping force/tightening torque diagram

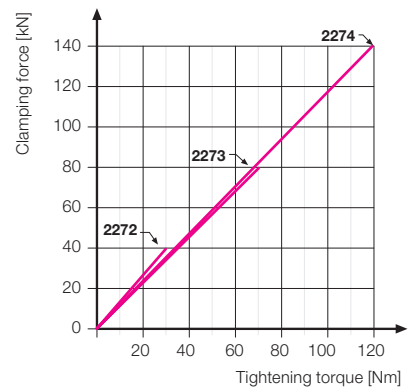

Important note

Before applying the tightening torque, the high-pressure spindle must be screwed against the clamping edge so that there is no play. If the parts are not rigid, tighten the high-pressure spindle using the hexagon nut SW2 until there is no play.

The clamping screws are permanently lubricated and maintenance free in case of normal operating conditions.

Application example



Clamping force	[kN]	40	80	140
Clamping stroke	[mm]	1.5	2.2	2.5
Max. tightening torque	[Nm]	30	70	120
Max. static load	[kN]	80	160	240
a	[mm]	62	75	90
b	[mm]	73	90	110
Ø d	[mm]	19	28	39
g	[mm]	M36 x 3	M48 x 3	M64 x 4
Monitoring of clamping stroke s	[mm]	5	7.5	8.5
SW 1	[mm]	13	17	19
SW 2	[mm]	30	41	55
Weight	[kg]	0.5	2.0	2.5
Part no.		2272210	2273210	2274210

Other sizes and threads (e.g. inch) are available on request.