

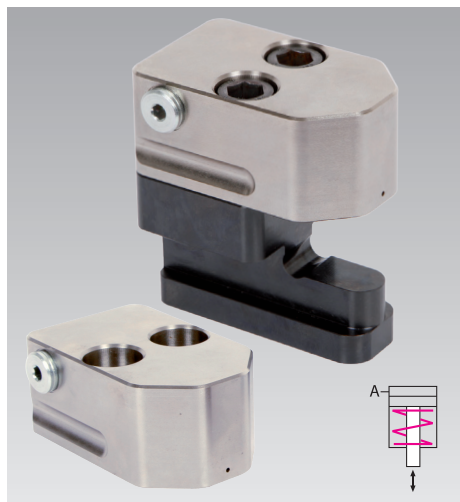

**Sliding Clamps compact**

single acting, with spring return

max. operating pressure 400 bar, clamping force from 19 to 78 kN



**Advantages**

- High clamping force in combination with small size and low weight
- Ergonomic T-slot adapter for easy insertion
- High-quality surface protection on the clamping block
- Clamping block rounded and thus optimum adaptation in narrow construction spaces
- Safe handling by special recessed grip
- T-slot 14, 18, 22 and 28 mm are available
- Total stroke 8 and 12 mm
- Die standardisation with regard to the width and depth is not required
- Easy to retrofit

**Installation option**

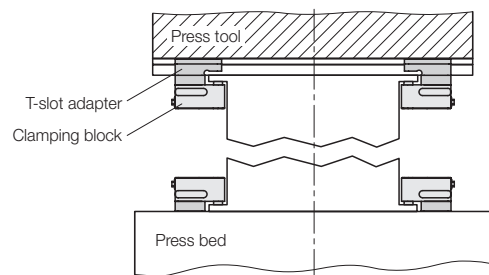

**Application**

The "compact" sliding clamp is a hydraulic clamping element, used with minimum space requirements for clamping and locking on machines and plants, on press bed and ram. Due to the manageable and rounded design, "compact" sliding clamps are especially suitable where space is limited as, for example, on high-speed punching presses. The use is possible at ambient temperatures up to a maximum of 120°C.

**Description**

Manual positioning of the sliding clamp in the T-slots of the press ram or bed. Clamping on the die clamping edge by the application of hydraulic pressure to the piston and unclamping by spring force.

The "compact" sliding clamp consists of a hydraulic clamping block which will be fixed with two screws to a T-slot adapter.

The clamping block can also be directly screwed without T-slot adapter and can be ordered separately.

**Application examples**



Sliding clamps with T-slot adapter in the press bed and ram

**Hydraulic clamping block**

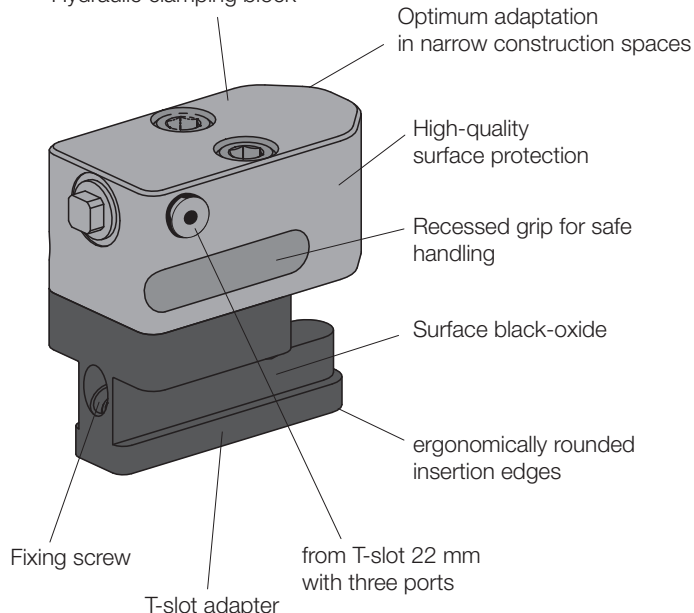

# Technical data Dimensions

## Sliding clamp compact

### Hydraulic sliding clamp complete, with T-slot adapter

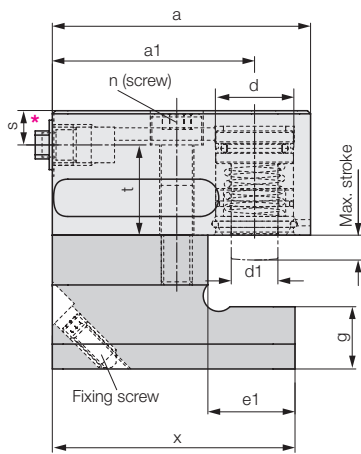

\* From T-slot 22 mm with hydraulic ports at the rear and at the side

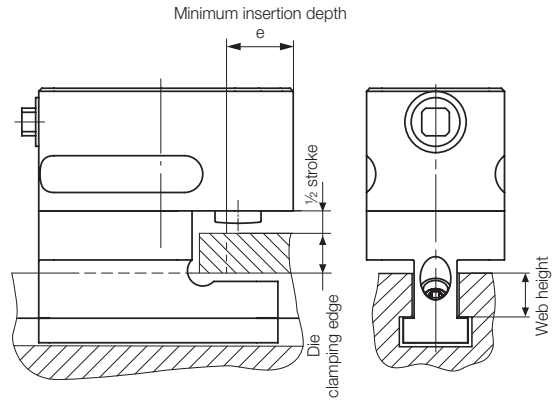
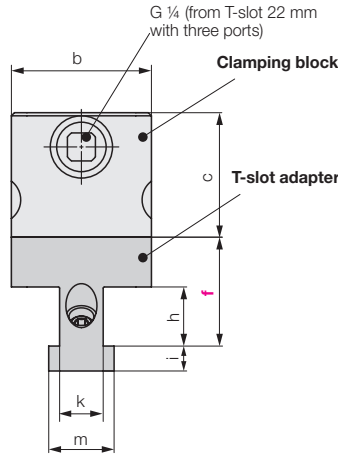
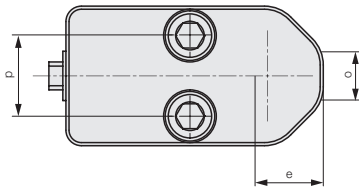

#### Functional dimension "f":

= 1/2 stroke  
+ die clamping height  
+ web height of the T-slot

Please specify when ordering.

#### Example of ordering

**8 2202 1855 / F60**

Sliding clamp  
Clamping force: 19.6 kN

T-slot  
18 mm

Functional dimension "f" [mm]  
please specify when ordering

T-slot as per DIN 650	[mm]	14	18	22	22	28	28
Clamping force at 400 bar	[kN]	19.6	19.6	32	50	50	78
Stroke	[mm]	8	8	8	8	8	12
Oil volume	[cm <sup>3</sup> ]	4	4	7	10	10	24
Dimension "f" min.	[mm]	30	41	50	50	55	60
Dimension "f" max.	[mm]	75	90	106	106	112	117
a	[mm]	83	83	104	111	111	132
a1	[mm]	65	65	81	85	85	99
b	[mm]	45	45	65	65	65	80
c	[mm]	40	40	47	50	50	75
d	[mm]	25	25	32	40	40	50
d1	[mm]	15	15	15	20	20	25
e (min. insertion depth)	[mm]	22	22	28	31	31	38
e1	[mm]	28	33	41	48	48	60
g	[mm]	20	24	32	32	42	42
h	[mm]	19	25	30	30	37	37
i	[mm]	8	10	14	14	18	18
k	[mm]	14	18	22	22	28	28
m	[mm]	21	28	35	35	44	44
n (screw DIN 912, 10.9)		M10	M10	M16	M16	M16	M20
o	[mm]	18	18	20	20	20	28
p	[mm]	26	26	36	36	36	43
r	[mm]	40	40	50	50	50	57
s	[mm]	11	11	12	12	12	17.5
t	[mm]	29	29	29	32	32	53
x	[mm]	78	83	104	104	104	132

#### Clamping block with T-slot adapter

Weight	[kg]	1.5	2.9	3.6	3.9	4.5	7.5
Part no.		8 2202 1455	8 2202 1855	8 2203 2255	8 2204 2255	8 2204 2855	8 2205 2855

#### Clamping block, separate

Weight	[kg]	0.7	0.7	2.0	2.3	2.3	4.9
Part no.		8 2202 1305	8 2202 1305	8 2203 1305	8 2204 1305	8 2204 1305	8 2205 1305

Please consult us if aggressive spray is used.  
Max. operating pressure 400 bar, max. operating temperature 120 °C.  
Further sizes and special versions are available on request

## Accessories

### Parking station

accommodates the sliding clamp during die change

T-slot as per DIN 650 [mm]	14	18	22	28
a [mm]	21	25	33	43
k [mm]	23	30	37	46
i [mm]	8	10	14	18
g [mm]	20	24	32	42

**Parking station complete** (with bracket and spacer bar)

**Part no.** 82754 1450 82754 1850 82754 2250 82754 2850

**Bracket**  
**Part no.** 82754 1400 2754 180 2754 220 2754 280

**Spacer bar**  
**Part no.** 50495 1400 2754 500 2754 500 2754 500

Values in brackets for 14 mm T-slots

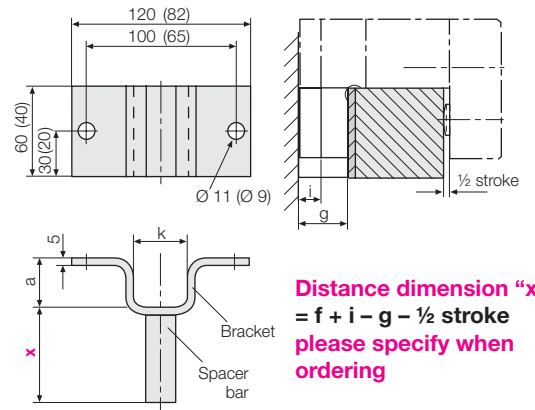

**Distance dimension "x"**  
**= f + i - g - 1/2 stroke**  
**please specify when ordering**

### Angular rotary coupling (M 8S / G 1/4)

**Part no. 9208 176**

For easier handling when changing dies.  
Max. operating pressure 400 bar

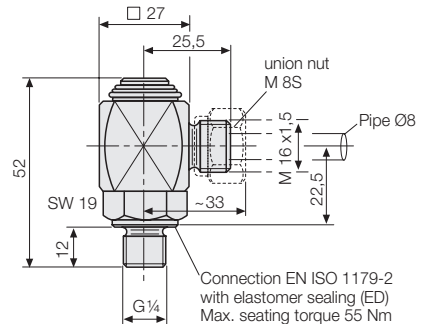

### Hydraulic high-pressure hoses

assembled ready for connection  
max. operating pressure 250 / 500 bar

High-pressure hoses are used for energy and signal transmission in hydraulic systems. The hose lengths should be generously dimensioned to avoid kinks, abrasion marks, torsion, tensile and compressive stress and unacceptable bending radii.

#### Hose structure

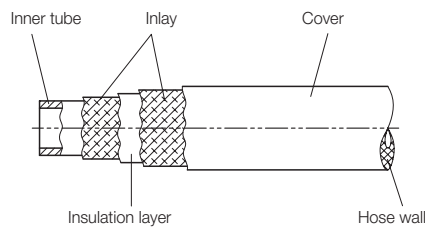

#### Hose union

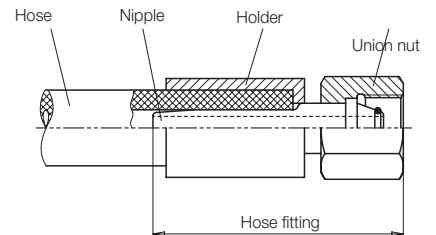

High-pressure hose	ND	4	4	6.3	6
Max. operating pressure	[bar]	250	500	250	500
Port size		8L	8S	8L	8S
Union nut		m8L (M 14x1.5)	m8S (M 16x1.5)	m8L (M 14x1.5)	m8S (M 16x1.5)
SW	[mm]	17	19	17	19

Preferred lengths	L =	500	1000	1600	2500
	[mm]	93751 00500	93752 00500	93206 00500	93706 00500
	[mm]	93751 01000	93752 01000	93206 01000	93706 01000
	[mm]	93751 01600	93752 01600	93206 01600	93706 01600
	[mm]	93751 02500	93752 02500	93206 02500	93706 02500

Other hose connections left / right on request. For further information and technical data, see data sheet WZ 11.3800

### Accessory

Hose holder made from Delrin

**Part no. 55065 0003**

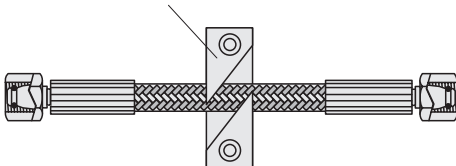

### Other accessories

#### Hydraulic power units

see product group 7

#### Hydraulic accessories

see product group 11